

# LANNA' table

design: Noè Duchaufour Lawrance / 2017

# KUNDALINI

Lampada da tavolo. Diffusore in vetro opale incamiciato e soffiato. Struttura in metallo verniciato.

Table lamp. Opal diffuser made of two layers of blown glass. Metallic coated structure.



## CERTIFICAZIONI - CERTIFICATIONS



Apparecchio di classe II  
Product in class II

IP20

Apparecchio per uso interno  
Product for indoor use



Apparecchio conforme alla direttiva europea 2014/35/EU  
Product in conformity with the European directive 2014/35/EU



Apparecchio di illuminazione da smaltire secondo la direttiva EU 2002/96/EC  
This lamp must be disposed in conformity with the EU directive 2002/96/EC

## DIMENSIONI - DIMENSIONS

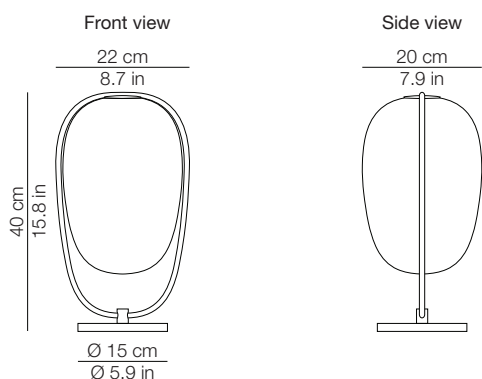

## IMBALLO - PACKAGING

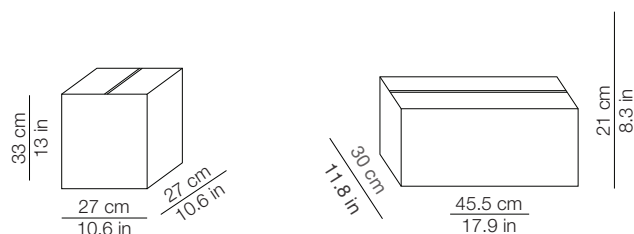

Volume: 0.024 m<sup>3</sup> / 0.850 ft<sup>3</sup>  
Gross weight: 2.02 kg / 4.44 lbs

Volume: 0.026 m<sup>3</sup> / 0.932 ft<sup>3</sup>  
Gross weight: 1.96 kg / 4.31 lbs

## MATERIALI E FINITURE - MATERIALS AND FINISHINGS

diffusore  
diffuser

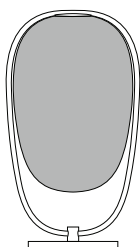

bianco - white

ottone - brass



nero - black  
RAL 9005  
matt



struttura  
structure

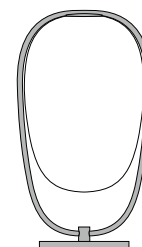

vetro opale incamiciato e soffiato  
two layers of blown glass

struttura in metallo verniciato  
metallic coated structure

## INFORMAZIONI AGGIUNTIVE - FURTHER INFORMATION

230V  
or  
120V

Alimentazione  
Feeding



Lampadine - Bulbs  
1 x max20W E27 (E26 US) Ø max 60mm - Fluorescent  
or 1 x 10W E27 (E26 US) Ø max 60mm - Led



Energy efficiency class from A+ to E

Lampada da tavolo  
Table lamp



Cavo di alimentazione trasparente  
Spina EU, USA o UK  
Transparent cord set  
EU, USA or UK plug



Interruttore rompifilo trasparente  
Transparent loose switch



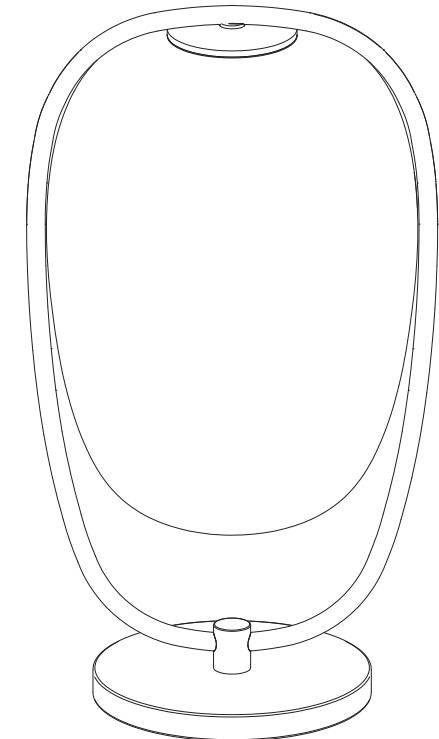

**ISTRUZIONI DI MONTAGGIO  
ASSEMBLY INSTRUCTIONS  
MONTAGE-ANLEITUNG  
INSTRUCTIONS DE MONTAGE  
INSTRUCCIONES DE MONTAJE**

**LANNÀ table** Noè Duchaufour Lawrance, 2017

KUNDALINI S.R.L. T +39 02 365 389 50  
Viale L. Da Vinci, 277 F +39 02 365 389 64  
20090 Trezzano S/N info@kundalini.it  
(Milano) - Italy www.kundalini.it

**ATTENZIONE**

La sicurezza dell'apparecchio è garantita con l'uso appropriato delle seguenti istruzioni, pertanto è necessario conservarle.

Togliere sempre la tensione prima di operare sull'apparecchio.  
Per pulire la lampada non usare mai prodotti abrasivi o detergenti aggressivi.  
Se il cavo esterno di questo apparecchio viene danneggiato, deve essere sostituito esclusivamente dal costruttore, dal suo servizio assistenza, o da personale qualificato equivalente, al fine di evitare pericoli.

Kundalini non effettuerà nessuna sostituzione se non dopo aver accertato la natura del difetto.

**WARNING**

The safety is guaranteed by the appropriate use of the following instructions, so you must keep them.

Always disconnect the main voltage before working on the appliance.  
Never use abrasive products or aggressive detergents for cleaning the lamp.  
If the external cable of this appliance is damaged, it must be replaced by the manufacturer, its after sales service or other equivalent qualified person only in order to avoid any danger.

Kundalini will not provide a replacement until the nature of defect has been determined.

**ACHTUNG**

Die Sicherheit dieses Artikels wird nur durch die strikte Befolgung der nachfolgenden Betriebsanleitung gewährleistet. Bitte heben Sie diese unbedingt auf.  
Vor allen Arbeiten ziehen Sie bitte den Stecker aus der Dose.

Für die Reinigung der Lampe niemals Schleifmittel oder aggressive Reinigungsmittel verwenden

Sollte das Außenkabel der Lampe beschädigt werden, ist es ausschließlich vom Service-Dienst des Herstellers oder gleichwertigen, qualifiziertem Personal auszutauschen, um somit Gefahren zu vermeiden.

Kundalini leistet grundsätzlich erst nach einer gründlichen Überprüfung Ersatz.

**ATTENTION**

La sûreté de l'appareil n'est garantie qu'en suivant scrupuleusement les instructions ci-après. Il est donc nécessaire de les conserver.

Isoler l'appareil du secteur avant toute manipulation.  
Pour nettoyer la lampe, ne jamais utiliser de produits abrasifs ou de nettoyeurs agressifs.

Si le câble externe de cet appareil est endommagé, il doit être remplacé uniquement par les soins du constructeur, par son service après-vente ou bien par le personnel équivalent, et ce afin d'éviter tout danger.

Kundalini ne remplacera aucun appareil sans en avoir pu vérifier le défaut.

**ATENCIÓN**

La seguridad del aparato está garantizada sólo con el uso apropiado de las instrucciones siguientes, por lo tanto es necesario atenderlas puntualmente.

Desconectar siempre la alimentación antes de trabajar en el aparato.  
Nunca utilice productos abrasivos o detergentes agresivos para limpiar la lámpara.

Si el cable externo de este aparato se deteriora será necesario sustituirlo; la sustitución podrá efectuarla exclusivamente el fabricante, su servicio de asistencia o personal cualificado equivalente para evitar peligros.

Kundalini no efectuará sustitución alguna hasta después de haber verificado la naturaleza del defecto.

Classe II-Class II-Schutzklasse II-Classe II-Clase II

IT-Apparecchio idoneo ad essere installato su superfici normalmente infiammabili.

EN-Appliance suitable for installation on normally inflammable surfaces.  
DE-Gerät, welches auf Oberflächen installiert werden kann, die normalerweise entzündbar sind.  
FR-Appareil destiné à être installé des surfaces normalement inflammables.  
ES-Aparato apto para ser instalado sobre superficies normalmente inflamables.

IT-Attesta la conformità del prodotto alle disposizioni delle direttive comunitarie.  
EN-It certifies the conformity of the product to the european community low voltage directive.

DE-Das Zeichen bestätigt die Übereinstimmung des Produkts mit den Bestimmungen der EU-Richtlinien.  
FR-Il atteste la conformité du produit aux dispositions des directives communautaires.  
ES-Certifica la conformidad del producto a las disposiciones de las normas de la comunidad.

IT-Il simbolo RAEE utilizzato per questo prodotto indica che quest'ultimo non può essere trattato come rifiuto domestico.

EN-The use of the WEEE symbol indicates that this product may not be treated as household waste.  
DE-Durch Verwendung des WEEE-Symbols weisen wir darauf hin, dass dieses Produkt nicht als normaler Haushaltsmüll behandelt werden darf.  
FR-L'utilisation du symbole WEEE indique que ce produit ne peut pas être traité comme déchet domestique.

ES-EI símbolo RAEE en un producto indica que éste no se puede eliminar como cualquier otra basura.

Lampadine-Bulbs-Leuchtmittel-Ampoules-Bombillas:  
fluo 1x max 20W E27 (E26 US)



or 1 x 10W E27 (E26 US)



Energy efficiency class from A to A++

Alimentazione-Feeding-Spannung-Alimentation-Tensión de red:  
220-240V

①

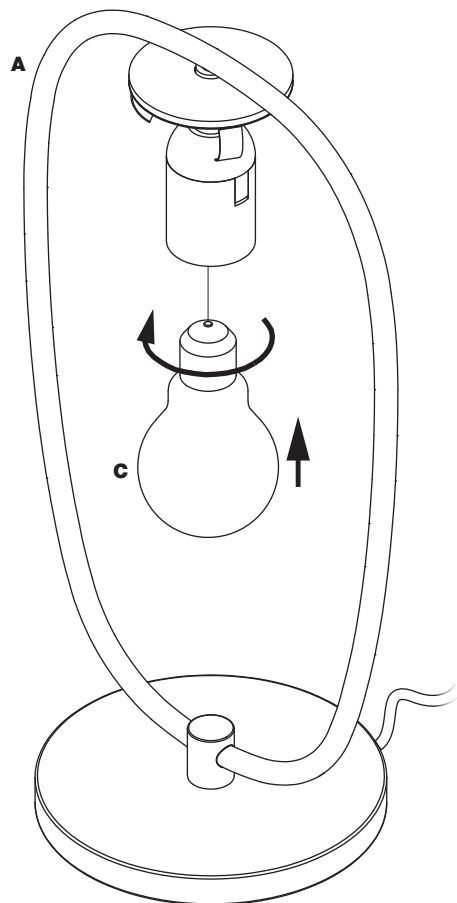

②

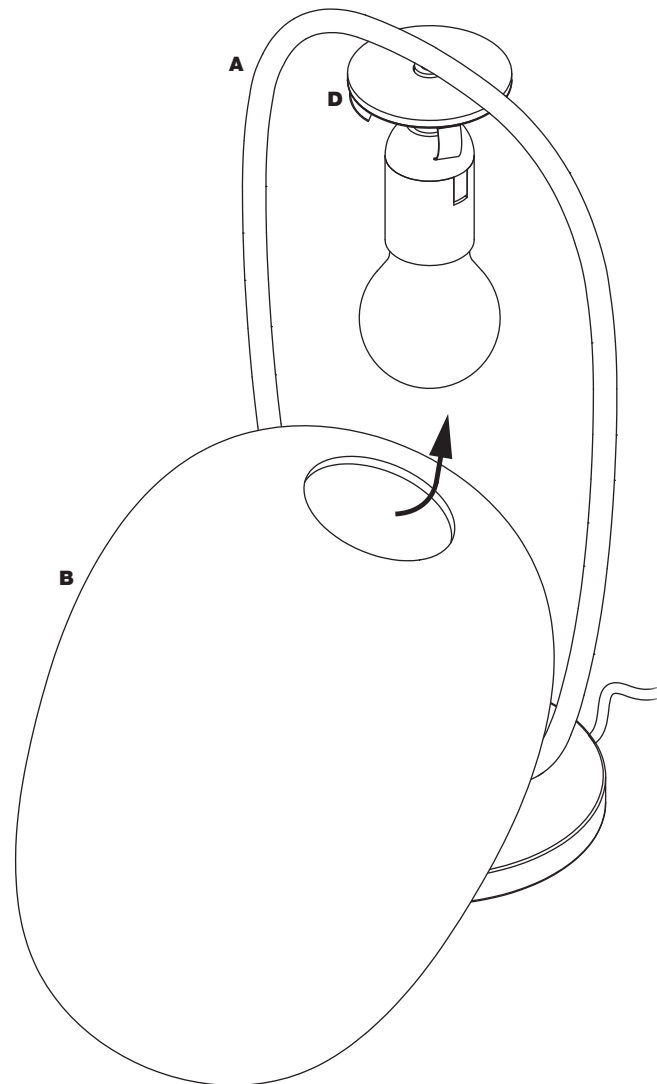

## ISTRUZIONI DI MONTAGGIO

Estrarre la struttura **A** e il diffusore **B** dagli imballi. Avvitare la sorgente luminosa **C** sulla struttura **A** - **Fig.1** -. Inserire il diffusore **B** sulla struttura **A** fissandolo sul supporto **D** - **Fig.2** -. Collegare la spina e accendere la lampada. Per sostituire la sorgente effettuare a ritroso le operazioni illustrate.

## ASSEMBLY INSTRUCTIONS

Extract the structure **A** and the diffuser **B** from the packaging. Screw the light bulb **C** on the structure **A** - **Fig.1** -. Insert the diffuser **B** upon the structure **A** fixing it on the support **D** - **Fig.2** -. Insert the plug and turn on the lamp. To replace the source, reverse the instructions shown.

## MONTAGE-ANLEITUNG

Nehmen Sie die Struktur **A** und das Glas **B** aus der Verpackung. Schrauben Sie die Glühbirne **C** auf das Gewinde der Struktur **A** - **Abb.1** -. Setzen Sie das Glas **B** vorsichtig auf die Struktur **A** und fixieren Sie dieses am Gewinde **D** - **Abb.2** -. Stecken Sie den Stecker in die Steckdose und schalten Sie die Lampe ein. Um die Glühbirne zu wechseln, folgen Sie dieser Anweisung in umgekehrter Reihenfolge.

## INSTRUCTIONS DE MONTAGE

Extraire la structure **A** et le diffuseur **B** des emballages. Visser la source **C** à la structure **A** - **Fig.1** -. Insérer le diffuseur **B** sur la structure **A** en le fixant sur le support **D** - **Fig.2** -. Brancher la prise et allumer la lampe. Pour remplacer la source répéter à l'envers les opérations décrites.

## INSTRUCCIONES DE MONTAJE

Extraer la estructura **A** el difusor **B** de los embalajes. Enroscar la fuente **C** en la estructura **A** - **Fig.1** -. Insertar el difusor **B** en la estructura **A** fijándolo al soporte **D** - **Fig.2** -. Conectar el enchufe y encender la lámpara. Para sustituir la fuente repetir de modo inverso las operaciones descritas.